

Model No : ALSXXXXA12-DW-30

Description : 12V Ultra Warm White Color LED Light Bar 30mm Pitch

LED Bar Unit

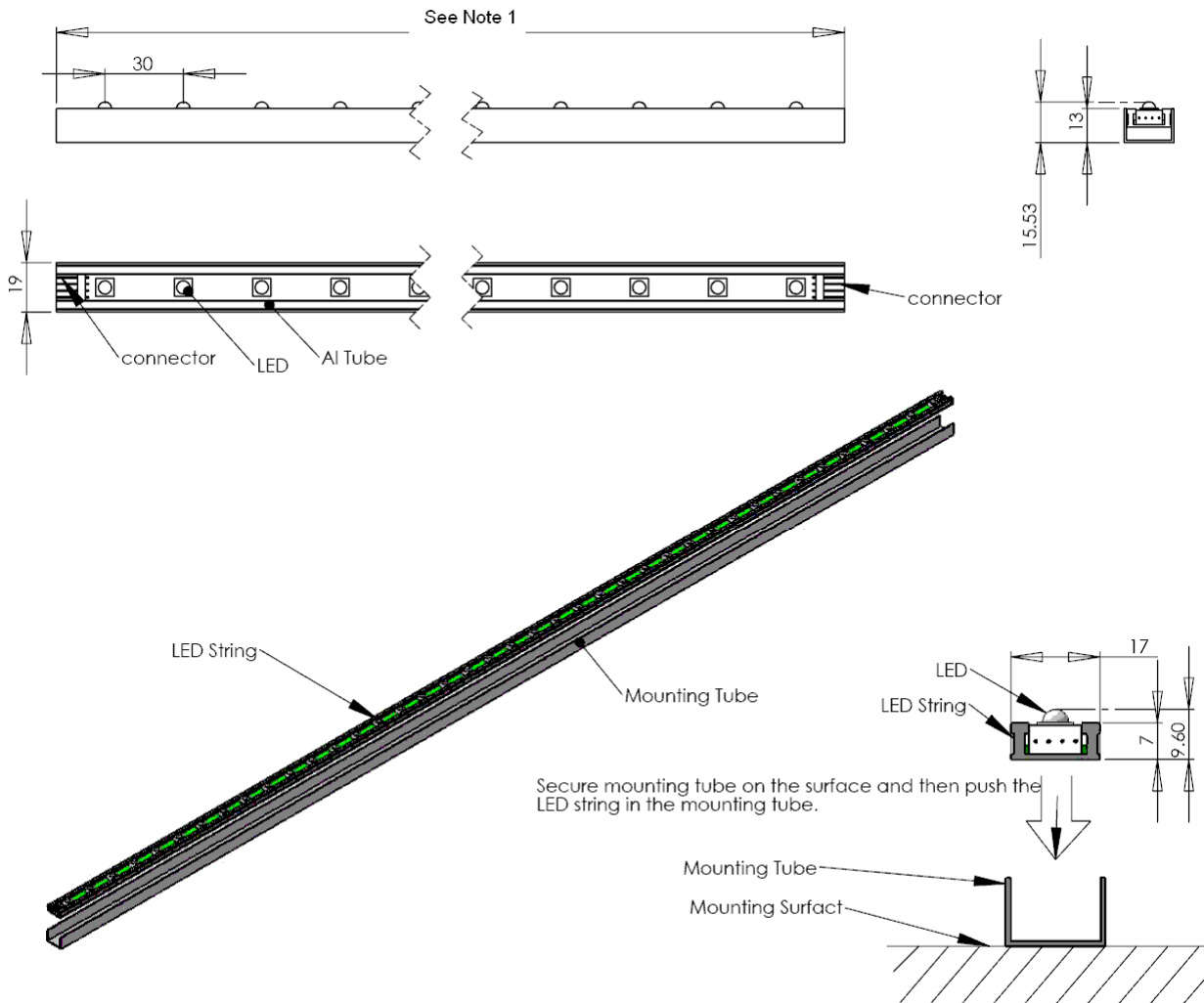

Features :

- Low Voltage Operation (Safe to touch)
- Compact and small size (Smaller than T-5).
- Can direct replace Fluorescent Tube.
- Can connect end to end to extend to very long string
- ESD Protection
- Easy mounting,
- Water Proof coating (Except connector)
- Low installation cost.
- Each LED Constant current control.
- Special Thermo design makes it low working temperature.
- Dimmable

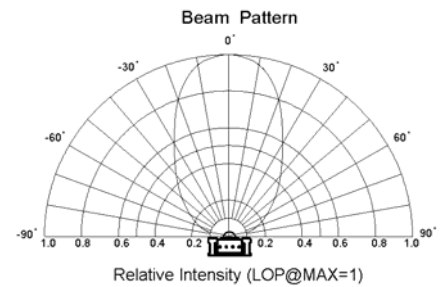

Connector polarity

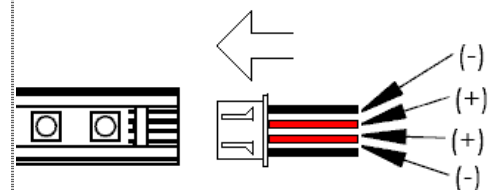

Wire Connector Diagram

SPECIFICATION

LED Bar Unit

Electric Specification:

- Operation Voltage 11.0V-12V
- Color 2800-3500K
- Viewing Angle: 70 Deg.
- Life span: 20,000 hour.
- IP rate : IP62
- Housing and mounting material : Aluminum
- Operation Temperature : -30°C – 40°C
- Storage Temperature : -40°C – 60°C
- Max end by end connection length 5 Meter

Model No	Total Length	LED Qty	Power Consume	Total Lumens	Weight	Dimension
ALS300A12-DW-30	322mm	10	2.4W	190ml	100G	12 X 19 X 322mm
ALS600A12-DW-30	622mm	20	4.8W	380ml	200G	12 X 19 X 622mm
ALS900A12-DW-30	922mm	30	7.2W	570ml	300G	12 X 19 X 922mm
ALS1200A12-DW-30	1222mm	40	9.6W	720ml	400G	12 X 19 X 1222mm
ALS1500A12-DW-30	1522mm	50	12W	950ml	500G	12 X 19 X 1522mm
ALS1800A12-DW-30	1822mm	60	14.4W	1140ml	600G	12 X 19 X 1822mm

Clip Mounting

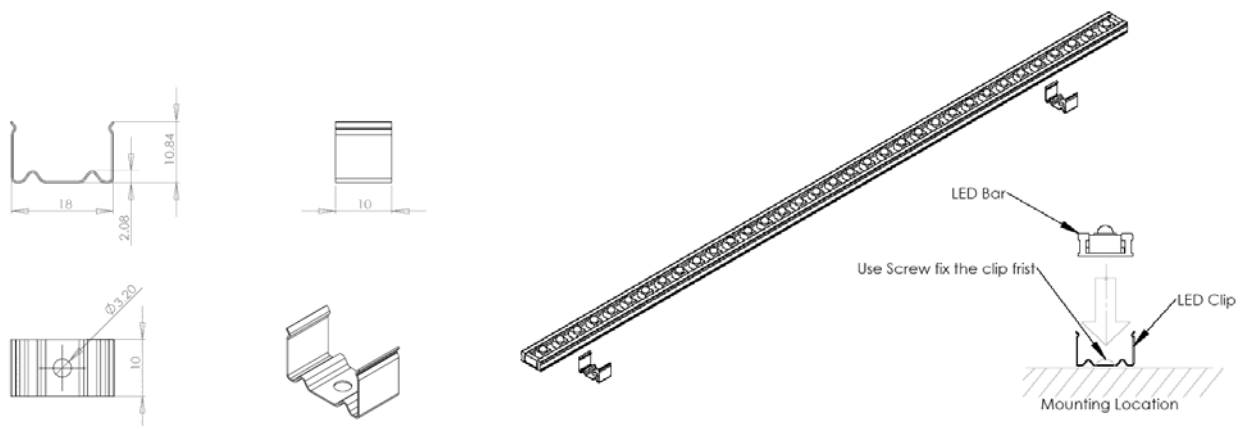

*Each LED Bar with 2 clips

SPECIFICATION

SWITCHING TYPE TRANSFORMER

Specification :

- Input Voltage : 110-240V AC 50/60 HZ
- Input Current : 1.3A
- Output Voltage: 12V DC
- Output Current : 10A (Max.)
- Max, Connect string: ALSXXXXA-XX-30 * 10M.
- Power consumption: 120W
- Type of connection: Terminal
- IP rate: IP20
- Housing Metal
- Operation temperature: -30°C – 50°C
- Storage Temperature : -40°C – 60°C
- Weight : 500G
- Dimension : 40 X 100 X 200mm
- Certificate CE



For Indoor application

TOROIDAL TYPE TRANSFORMER

Specification :

- Input Voltage : 220AC 50 HZ
- Input Current : 1.5A
- Output Voltage: 12V DC
- Output Current : 10A (Max.)
- Max, Connect string: ALSXXXXA-XX-30 * 12M.
- Power consumption: 120W
- Type of connection: Wiring
- IP rate: IP30
- Housing Metal
- Operation temperature: -30°C – 40°C
- Storage Temperature : -40°C – 40°C
- Weight : 1500G
- Dimension : 60 X 148 X 160mm
- Certificate : CE (Toroidal transformer only)

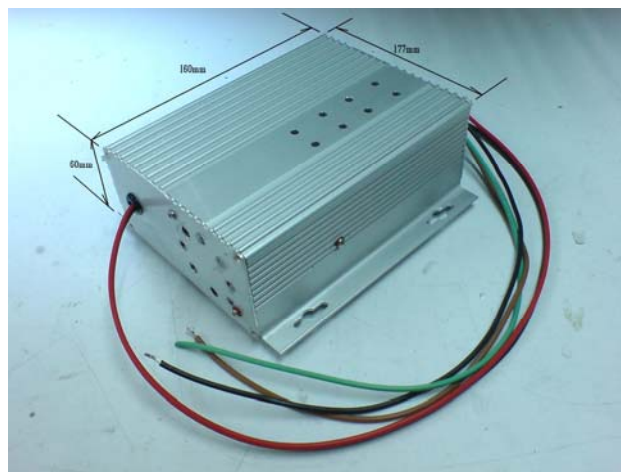

For dimmer application

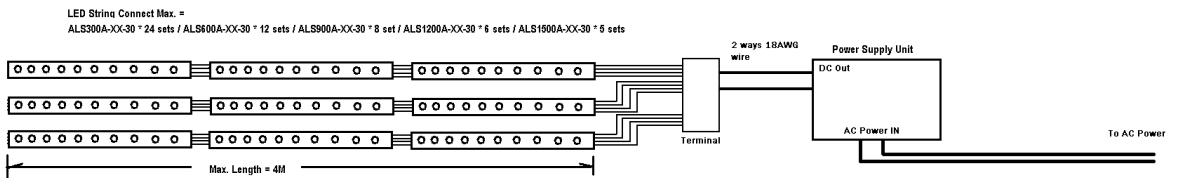
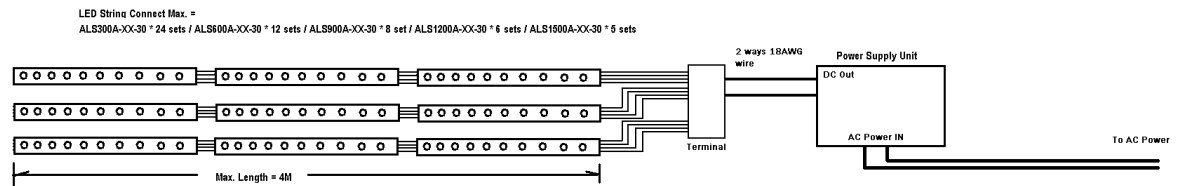
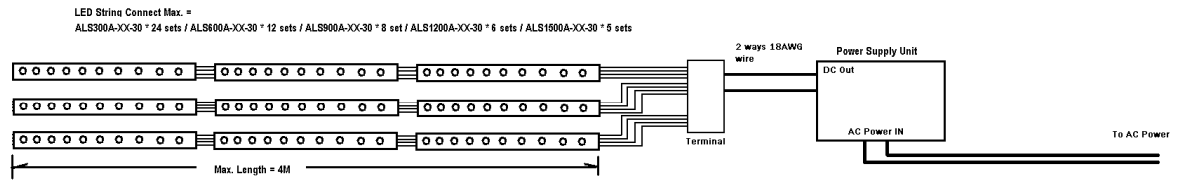
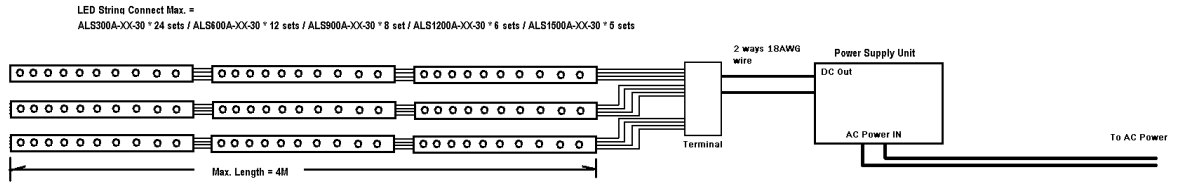

保安道住宅大廈



必發道住宅大廈



新城市廣場地下停車場

